

NCI Technologies Ltd presents:

# Microsoft® Office Word 2003 Training

**Great Word features**



# Course contents

- Overview: Great features in Word 2003
- Lesson 1: Reading layout view
- Lesson 2: International characters and symbols
- Lesson 3: Compare documents side-by-side
- Lesson 4: The horizontal ruler
- Lesson 5: Word count

# Overview: Great features in Word 2003

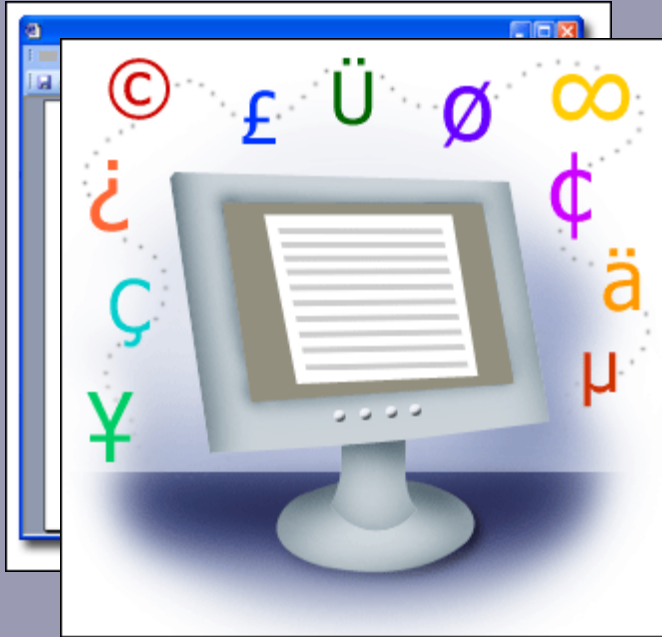

Have you ever wondered what's the easiest way to insert international characters or set tab stops in a document? Or how you can find out if your 700–word paper is complete?

Learn about five great features in Word. Some are brand new with Microsoft® Office Word 2003; others are features that you might have always been curious about.

# Course goals

- Use the new reading layout view.
- Insert international characters and symbols.
- Compare documents side-by-side.
- Use the full functionality of the horizontal ruler, including tab stops, margins, and hanging indents.
- Work with the word count feature.

# Lesson 1

## **Reading layout view**

# Reading layout view

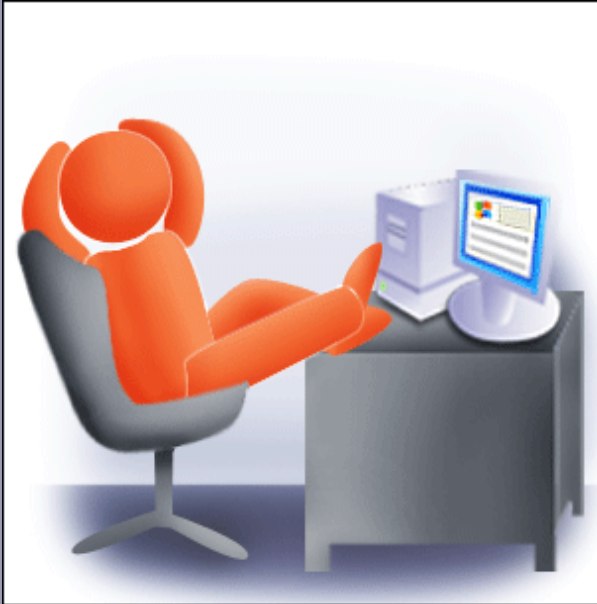

How often do you print long documents just because it's easier to read them on paper than it is on the screen?

If this sounds familiar, then the new **reading layout** view could be ideal for you.

# It's all about reading

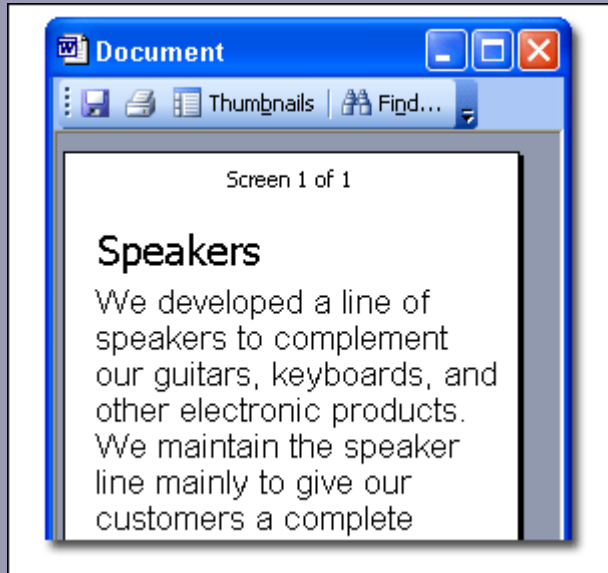

Reading layout view is all about reading documents. You will find that, with this feature, you can read documents on the screen that previously you would have printed.

Document in reading layout view

Great Word features

# It's all about reading

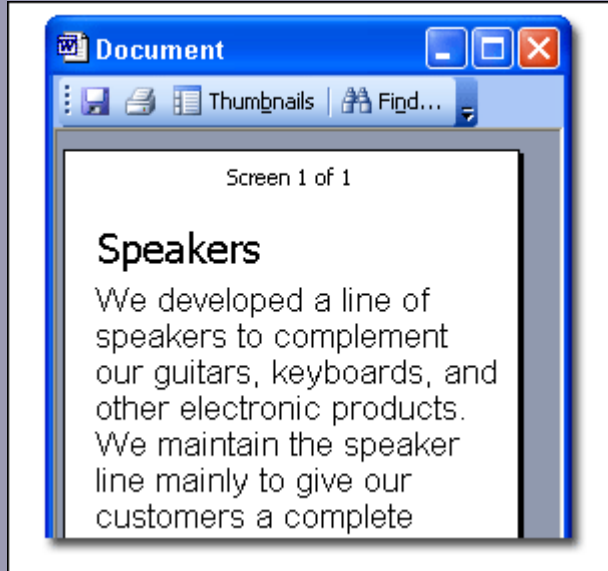

What reading layout view isn't:

- It isn't designed for writing. Although you can do small edits, if you want to make extensive changes to a document, you will be better off using another view, such as print layout.

Document in reading layout view

# It's all about reading

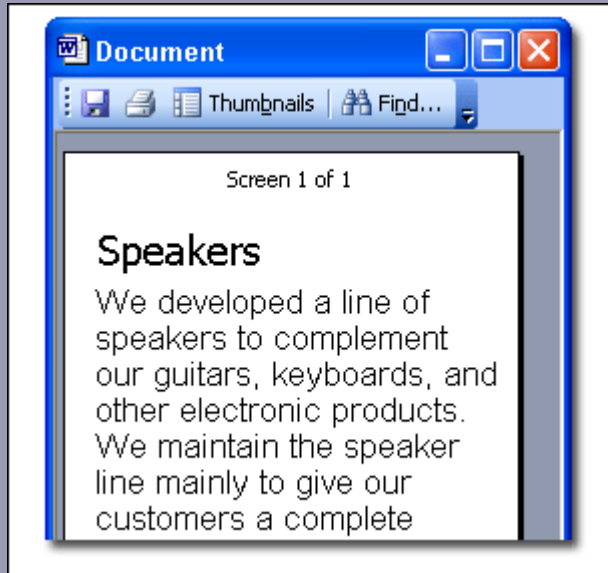

Document in reading layout view

What reading layout view isn't:

- It isn't an accurate representation of what the document will look like when printed—that's what the Print Preview command is for.
- It isn't the best way of viewing text boxes, graphics, or tables; it's ideal for long textual documents.

# Editing

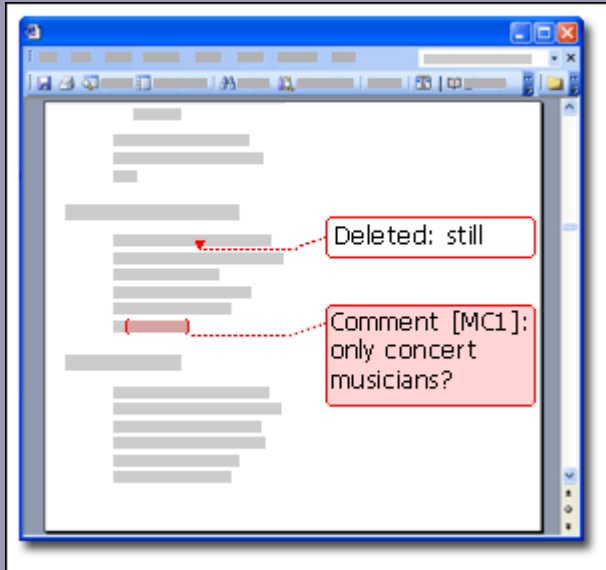

You can make small edits in reading layout view. In addition, if you want to make comments or track changes as you read, you can use the track changes and comments feature.

Reading layout view:  
changes and comments

# Editing

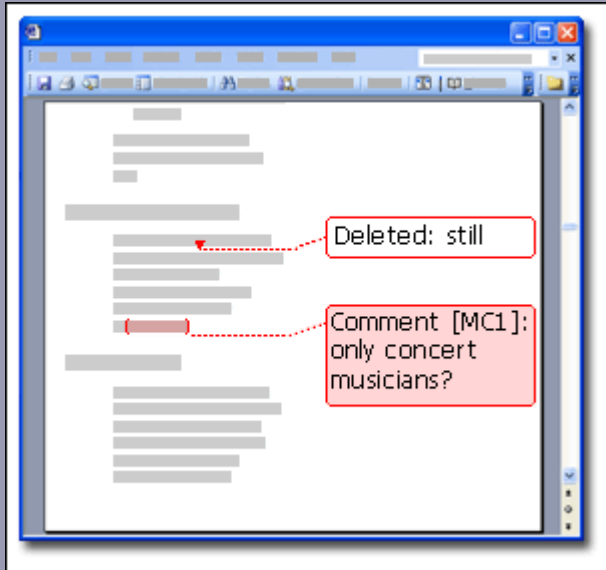

Reading layout view may open showing one or two screens, depending on a number of factors, such as the window size.

If the display is showing two screens and you add comments or tracked changes, it changes to one screen, as shown in the picture on the left.

Reading layout view:  
changes, comments

# The Reading Layout toolbar

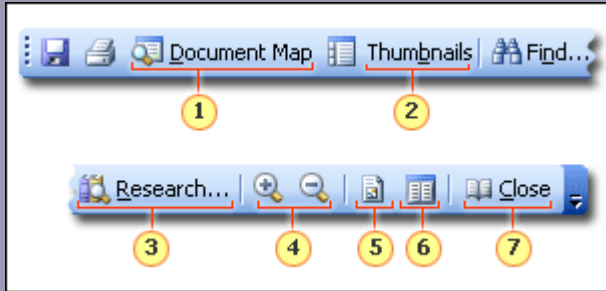

The **Reading Layout** toolbar

When you are in reading layout view, the **Reading Layout** toolbar is visible.

It contains a number of helpful buttons that you can use, such as the **Save**, **Print**, and **Find** buttons.

# The Reading Layout toolbar

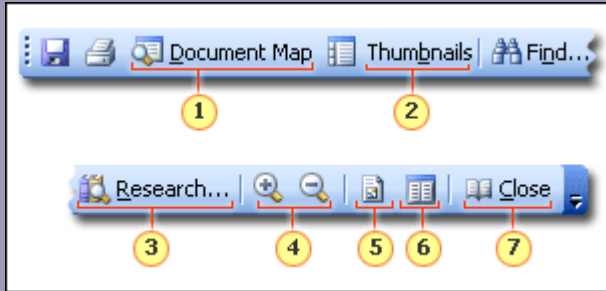

The **Reading Layout** toolbar

The Reading Layout toolbar has some specialized buttons:

- 1. Document Map:** Displays all the headings in a document on the left side of the window so that you can easily find a particular area of the document.

# The Reading Layout toolbar

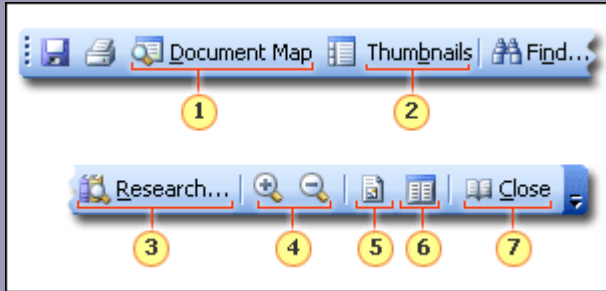

The **Reading Layout** toolbar

**2. Thumbnails:** Displays several pages of the document on the left side of the window in thumbnail format.

**3. Research:** Opens the Research task pane on the right side of the window so that you can look up information as you work through the document.

# The Reading Layout toolbar

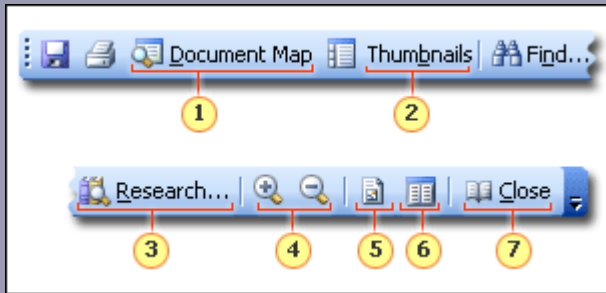

The **Reading Layout** toolbar

**4. Increase and Decrease Text Size:** Two buttons that give you the ability to make the text larger or smaller for reading purposes only without changing the font size.

**5. Actual Page:** Shows what the document would look like if you printed it. This is similar to print layout view.

# The Reading Layout toolbar

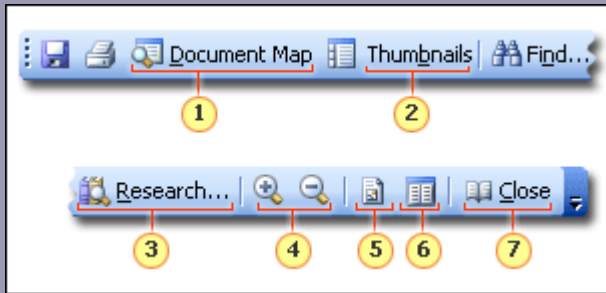

The **Reading Layout** toolbar

**6. Allow Multiple Pages:** Displays two pages side-by-side, as when reading a book. This setting is on by default, but the actual display depends on your window size.

**7. Close:** Takes you out of reading layout view.

# Why does it automatically open?

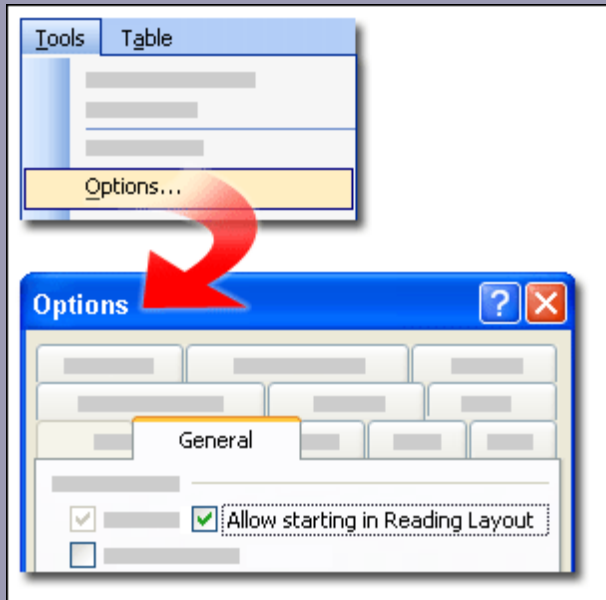

To read documents in reading layout view, click the **Read** button  on the **Standard** toolbar.

Or, on the **View** menu, click **Reading Layout**.

You can stop reading layout view from automatically opening.

# Why does it automatically open?

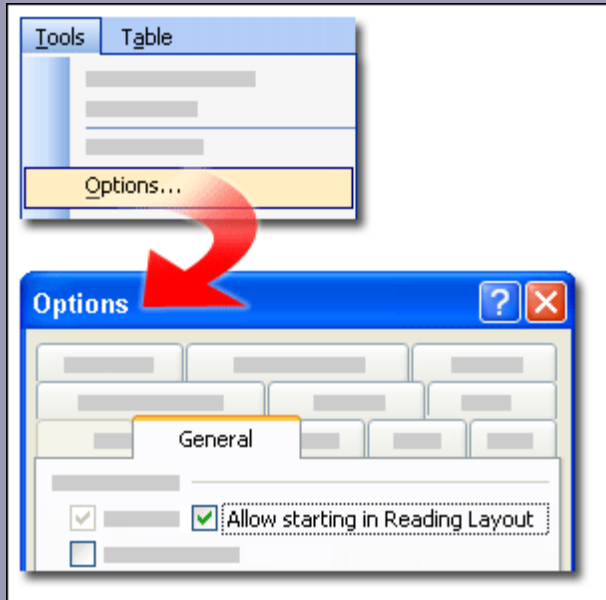

If you open a Word document from an e-mail attachment or from a Web site based on Microsoft® Windows® SharePoint® Services, it will automatically open in reading layout view.

You can stop reading layout view from automatically opening.

# Why does it automatically open?

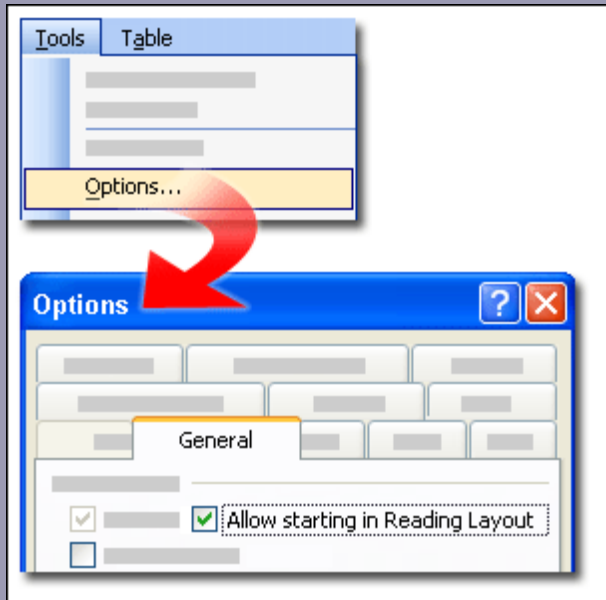

You can stop reading layout view from automatically opening.

Reading layout view is not a traditional Word view, in that you can't save a document in this view.

There is an exception to this rule: If you make ink annotations in reading layout view and then save the document, the document is saved in this view.

# Suggestions for practice

1. Explore reading layout view.
2. Explore the Reading Layout toolbar.

[Online practice](#) (requires Word 2003)

# Test 1, question 1

**To stop wasting paper, you've resolved to read more of your documents on-screen. In Word, which view would you use to do this? (Pick one answer.)**

1. Normal view.
2. Print layout view.
3. Print preview view.
4. Reading layout view.

# Test 1, question 1: Answer

Reading layout view.

Reading layout view is designed for reading. It's the next best thing to reading a document on paper.

# Test 1, question 2

**How do you make the text larger in reading layout view? (Pick one answer.)**

1. Increase the font size in the document.
2. Use the **Increase Text Size** button.
3. Change your screen resolution.
4. Use the Microsoft Magnifier.

# Test 1, question 2: Answer

Use the **Increase Text Size** button.

This will increase the size for reading only; it will not affect the document.

# Lesson 2

## **International characters and symbols**

# International characters and symbols



It's amazing how often you need to use a symbol or international character when you're producing a document.

Perhaps you're comparing U.S. dollars to yen, euros, and pounds sterling. Maybe you're writing to a customer with an umlaut in his or her name. Or, your science homework requires you to use the Greek alphabet.

# The Symbol dialog box

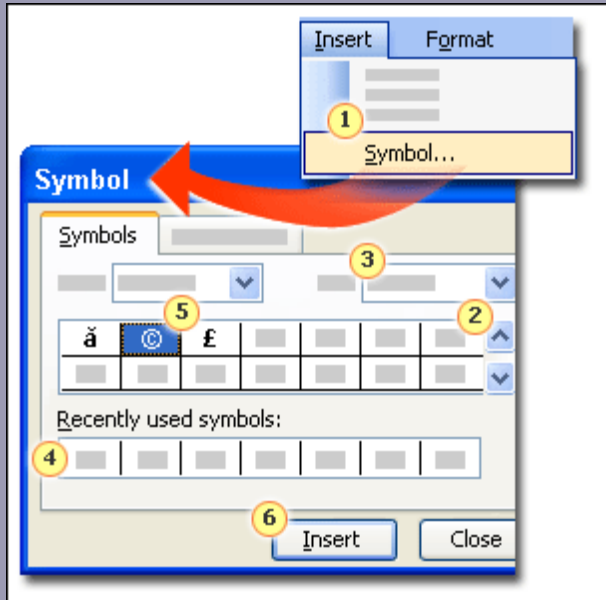

Symbols are inserted from the **Symbol** dialog box:

1. On the **Insert** menu, click **Symbol**, and then click the **Symbols** tab.
2. Scroll through the list to find the symbol you want.
3. You can use the **Subset** list to find a symbol quickly if you know what type of symbol it is.

Inserting a symbol from the **Symbol** dialog box

# The Symbol dialog box

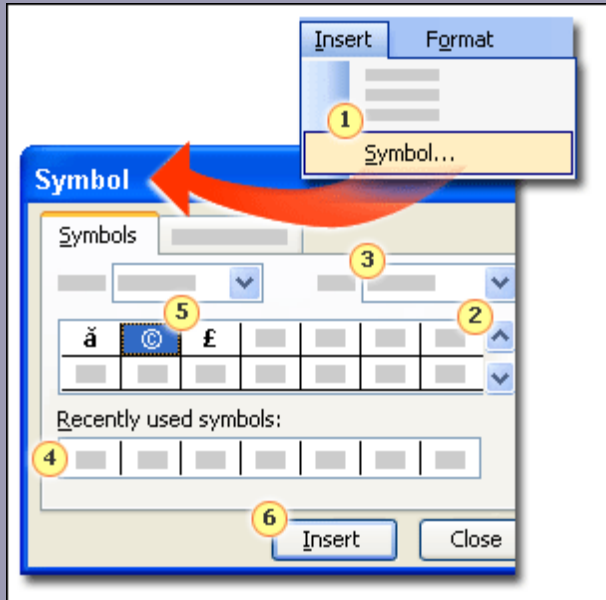

4. The **Recently used symbols** list updates automatically with the symbols you use most often.

5. When you've found your symbol, click it.

6. Click **Insert**.

Inserting a symbol from the **Symbol** dialog box

# Regular usage



If you use a particular character or symbol frequently, it's worth your time to set up a shortcut. Although a few shortcuts are already built into Word, you can also make your own.

Inserting the copyright sign: ©

# Regular usage



Inserting the copyright  
sign: ©

You have two main options for inserting characters and symbols quickly, both of which are available from the **Symbols** dialog box:

- Keyboard shortcuts
- AutoCorrect

# Regular usage



Inserting the copyright sign: ©

- **Keyboard shortcuts** are quite useful; in fact, many keyboard shortcuts are already built into Word—see the **Special Characters** tab in the **Symbol** dialog box.

You can even make your own by clicking the **Shortcut Key** button.

# Regular usage



Inserting the copyright sign: ©

- Type a sequence of letters, and the **AutoCorrect** feature in Word changes the letters to the symbol or character you want.

To use this method, you have to set up the AutoCorrect text (except for a few symbols), but you only have to do it once.

It's easier to remember than keyboard shortcuts.

# Suggestions for practice

1. Use the Symbol dialog box.
2. Use the two methods for shortcuts:
  - Keyboard shortcut
  - AutoCorrect
3. Use advanced symbol insertion.
4. Put it all together.

[Online practice](#) (requires Word 2003)

# Test 2, question 1

You need to insert a Greek letter into a Word document. Where will you find the Greek alphabet? (Pick one answer.)

1. **Tools** menu, **Language** command.
2. **Symbol** dialog box (**Insert** menu, **Symbol** command).
3. In the dictionary (**Tools** menu, **Spelling and Grammar** command).
4. You need to know the keyboard shortcut for the specific letter.

# Test 2, question 1: Answer

**Symbol** dialog box (**Insert** menu, **Symbol** command).

The Symbol dialog box contains many different symbols and special characters, including international alphabets. In this case, it's Basic Greek, and you can use the subset list to find it.

# Test 2, question 2

**Which of the following is a fast way to insert the registered trademark (®) symbol? (Pick one answer.)**

1. Insert a graphic of the ® symbol.
2. Type (tm).
3. Create your own keyboard shortcut.
4. Type (r).

# Test 2, question 2: Answer

Type (r).

This is a quick way of inserting the symbol using the AutoCorrect text built into Word.

# Lesson 3

**Compare documents  
side by side**

# Compare documents side by side

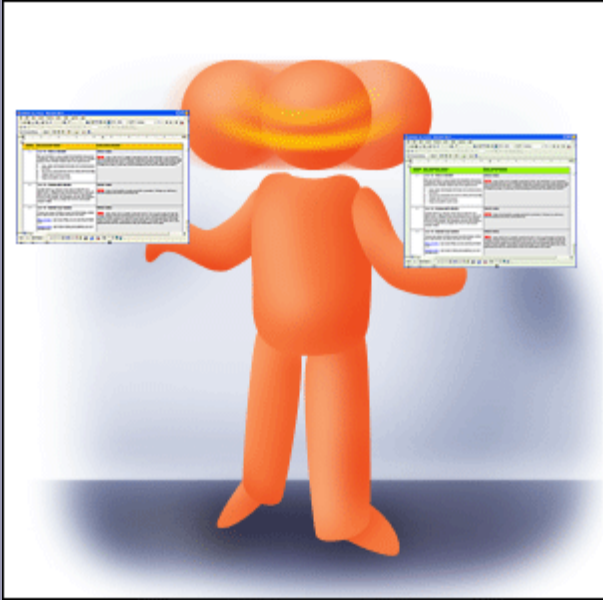

Have you ever wanted to see two documents side-by-side? Perhaps you wanted to compare documents containing related information?

Introducing you to the new **Compare Side by Side** feature in Word.

Ever tried to look at two documents at once?

# Open Compare Side by Side

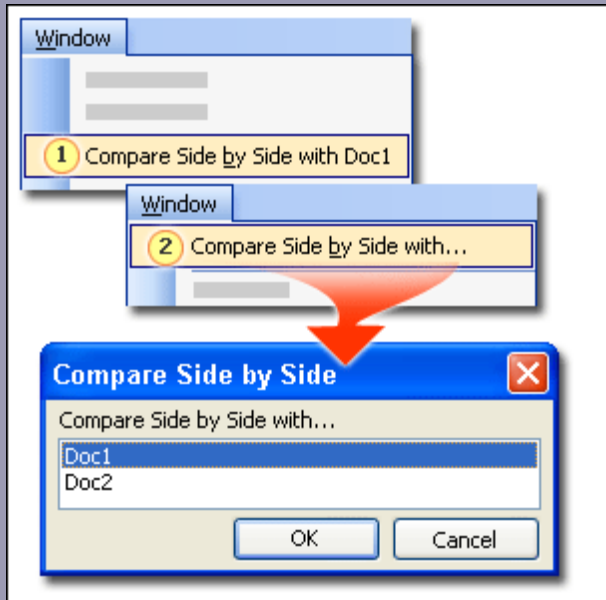

Imagine that you are a college professor and you have read two similar articles about the solar system.

You want to compare the two documents side by side to see just how similar they are.

# Open Compare Side by Side

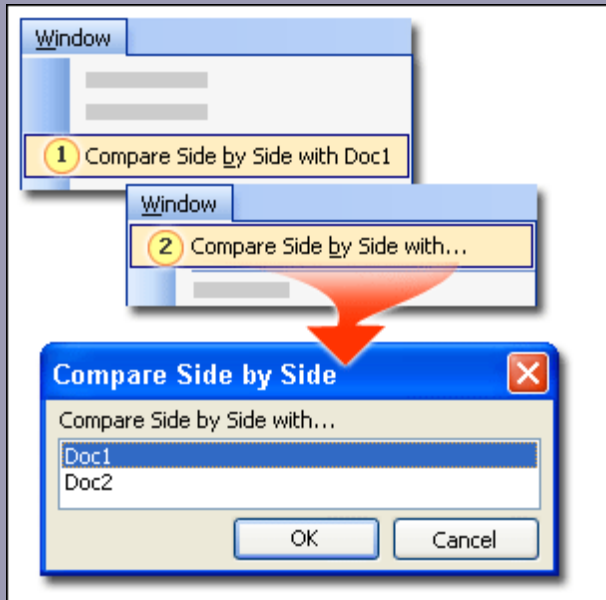

Open both documents, and in one document, click **Compare Side by Side** on the **Window** menu:

1. If you only have two documents open, the **Compare Side by Side** command automatically shows the other open document.
2. With more than two documents open, click **Compare Side by Side**, and, in the dialog box, choose the document you want to compare.

# Seeing double?

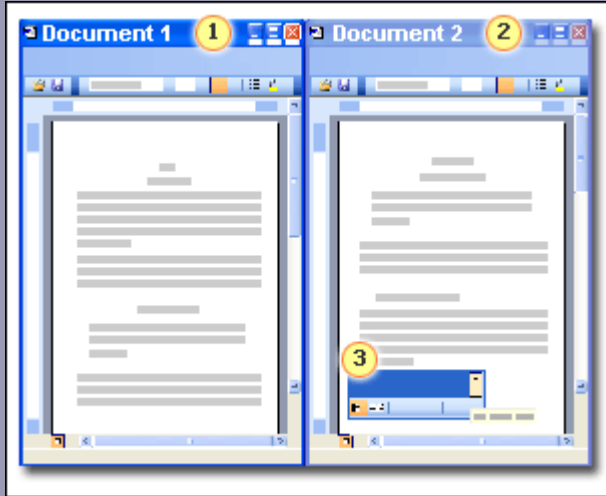

Comparing two documents side by side

When you compare documents side by side, this is what you see in the window:

1. The active document
2. The document for comparison
3. The **Compare Side by Side** toolbar, which helps you work in this view.

# Seeing double?

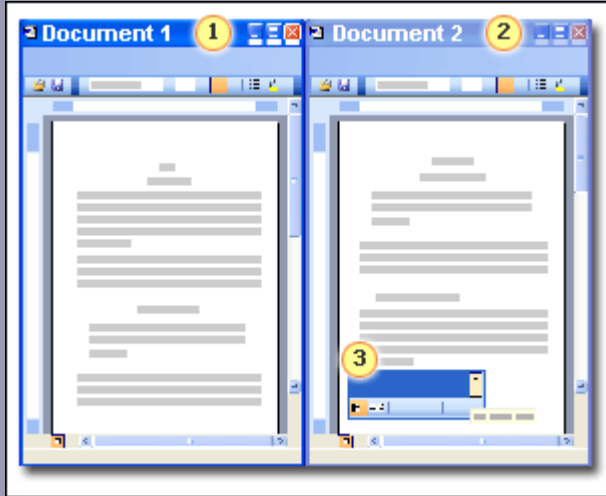

Comparing two documents side by side

The buttons on the **Compare Side by Side** toolbar include:

- **Synchronous Scrolling** button



- **Reset Window Position** button



- **Close Side by Side** button

# Suggestions for practice

1. Set up the documents to compare.
2. Compare the documents.

[Online practice](#) (requires Word 2003)

# Test 3, question 1

**When would you use the Compare Side by Side feature? (Pick one answer.)**

1. When you have to read two separate documents.
2. When you want to merge two versions of the same document.
3. When you want to compare two similar or related documents.

# Test 3, question 1: Answer

When you want to compare two similar or related documents.

This feature is ideal for looking at two similar documents to compare information in one against the other.

# Test 3, question 2

**Where do you open the Compare Side by Side feature? (Pick one answer.)**

1. The **Compare** and **Merge** command on the **Tools** menu.
2. The **Window** menu.
3. The **View** menu.

# Test 3, question 2: Answer

The **Window** menu.

The **Compare Side by Side** command is found on the **Window** menu because you're managing several windows.

# Lesson 4

## **The horizontal ruler**

# The horizontal ruler

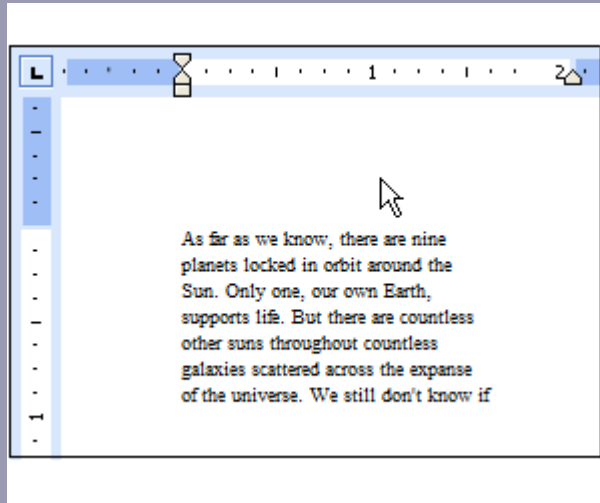

Animation: Right-click, and click **Play**.

You can use the horizontal ruler to quickly set up margins, tab stops, and hanging indents.

Many people ignore it and use the various dialog boxes instead. But once you know how to use it, you'll wonder how you ever managed without it.

# The horizontal ruler

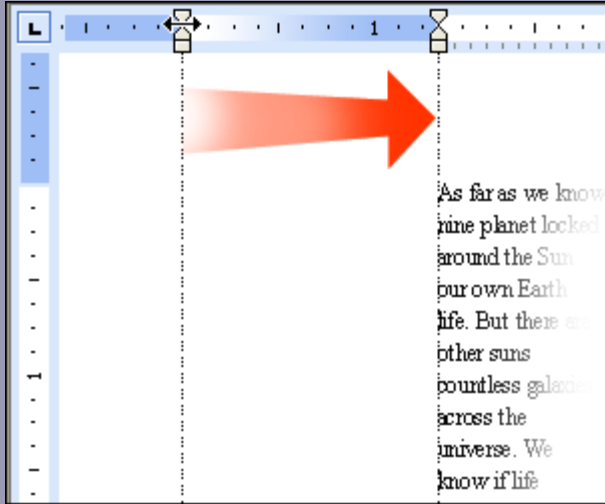

You can use the horizontal ruler to quickly set up margins, tab stops, and hanging indents.

Many people ignore it and use the various dialog boxes instead. But once you know how to use it, you'll wonder how you ever managed without it.

# Ruler basics

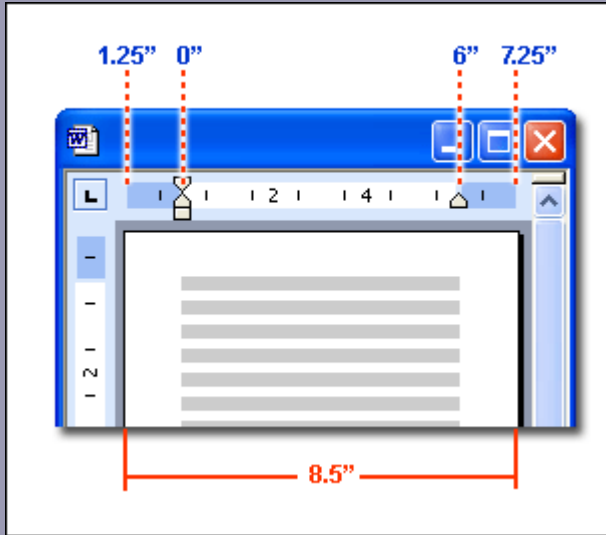

The ruler marks off the width of a page and follows the page setup information.

But the ruler measures from the left margin of a document, not the edge. So the scale on the ruler counts both to the left and the right, with the left margin being the start (or zero point) of the scale.

# Ruler basics

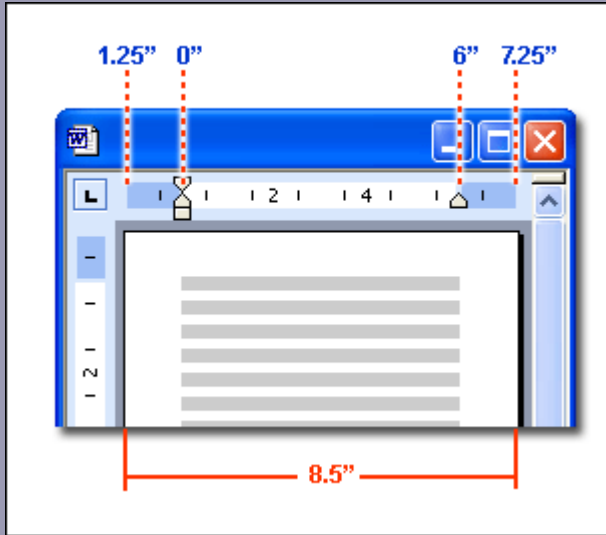

The ruler measures the width of the paper from the left margin (0").

In the example shown here, it's 7.25 inches to the right and 1.25 inches to the left of the margin, making a total page width of 8.5 inches. The width of the text area is 6 inches.

# Bits on the ruler

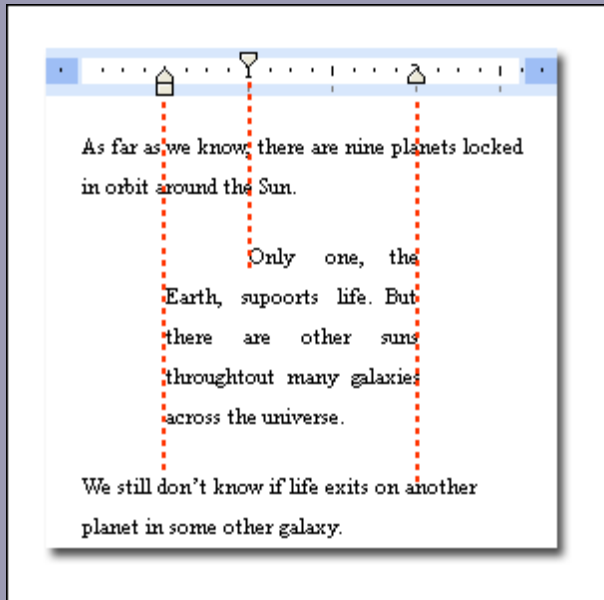



The sliding markers on the ruler are used to position paragraphs of text on a page. To set the indent for more than one paragraph, select all the text you want to adjust before setting the indents.

Paragraph indents are set by indent markers on the ruler.

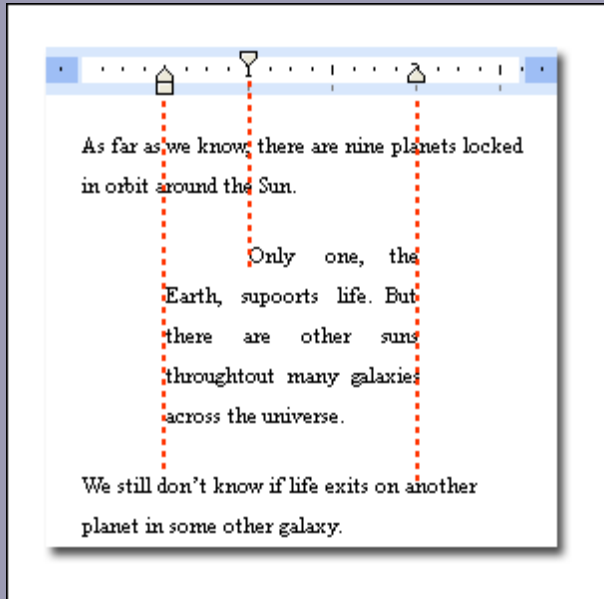
# Bits on the ruler





- The **First Line Indent**  positions the slider where you want the first line of a paragraph to start (or be indented).
- The **Hanging Indent**  positions the start of the second and all following lines of text.

Paragraph indents are set by indent markers on the ruler.

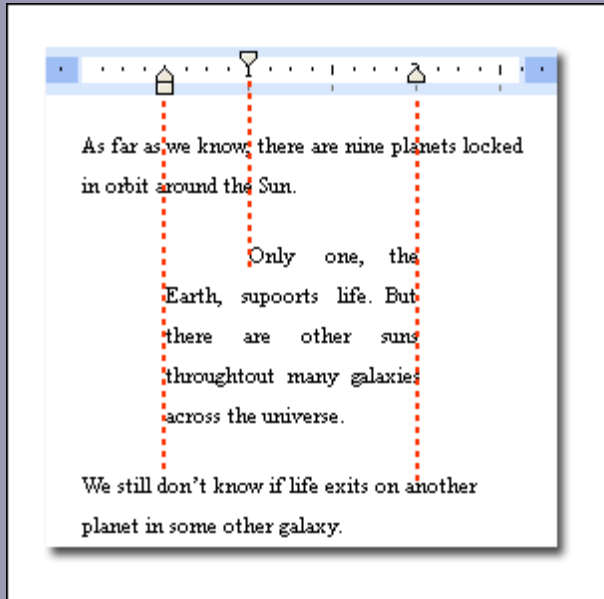
# Bits on the ruler



- The **Left Indent**  is used to move the hanging indent and first-line indent together, keeping a constant space between them.
- The **Right Indent**  positions the right indent of a paragraph.

Paragraph indents are set by indent markers on the ruler.

# Tab stops

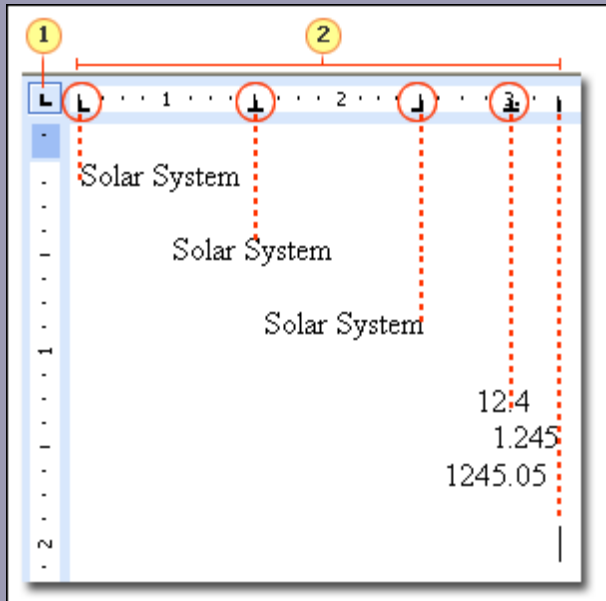

Quickly set tabs by clicking the tab selector at the left end of the ruler, choosing the type of tab you want, and then clicking the ruler at the location you want.

Tab selector and tab stops

# Tab stops

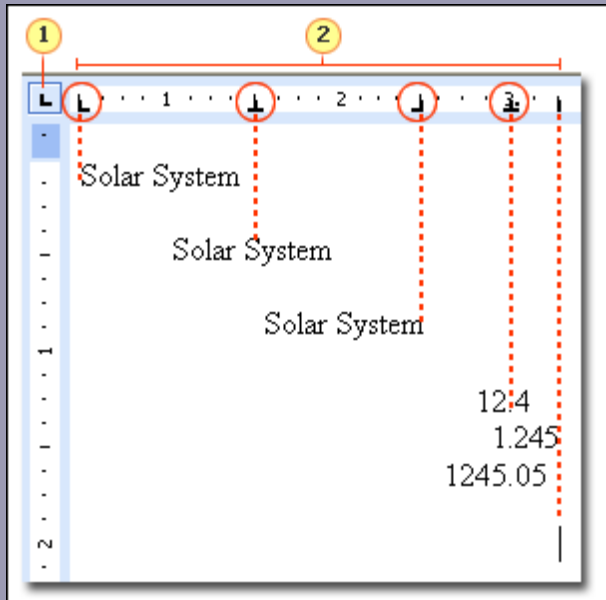

See the illustration at left:



1. The tab selector. Click to cycle through the types of tab stops.
2. Tab stops positioned along the horizontal ruler.

Tab selector and tab stops

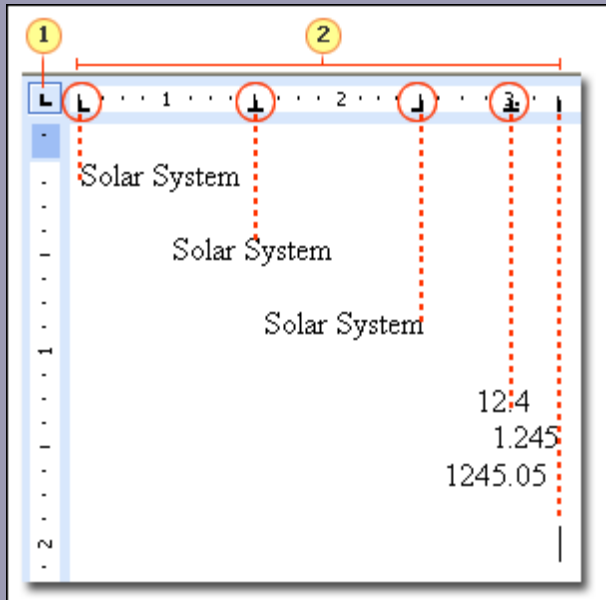
# Tab stops



Which type of tab stop should you use?



- The **Left Tab**  sets the start position of text that will then run to the right.
- The **Center Tab**  sets the position of the middle of the text.
- The **Right Tab**  sets the right end of the text. As you type, the text moves to the left.

Tab selector and tab stops

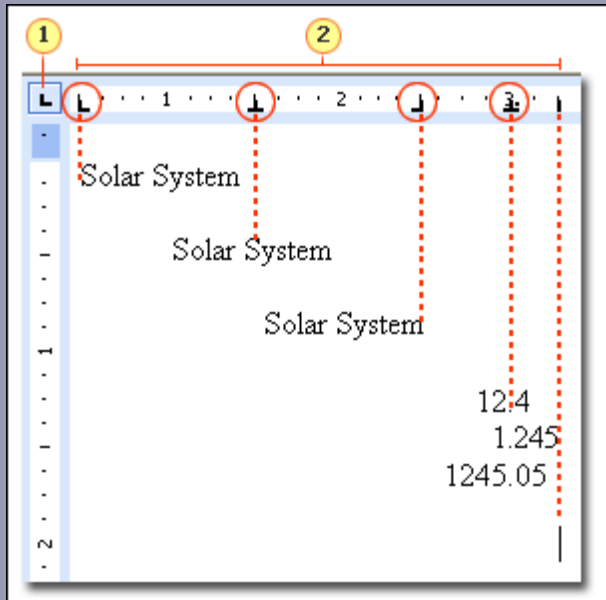
# Tab stops



Tab selector and tab stops

- The **Decimal Tab**  aligns text around a decimal point. Independent of the length of the figure, the decimal point will be in the same position.
- The **Bar Tab** , unlike the other tabs, doesn't position text. It inserts a vertical bar at the tab position.

# Suggestions for practice

1. Change document margins.
2. Use indents.
3. Set tab stops:
  - Get to know your tab stops.
  - Use tab stops.

[Online practice](#) (requires Word 2003)

# Test 4, question 1

**If you want to line up a list of figures, keeping the decimal point in the same place on each line, which type of tab stop do you use? (Pick one answer.)**

1. Left.
2. Right.
3. Bar.
4. Decimal.

# Test 4, question 1: Answer

Decimal.

# Test 4, question 2

**What is the quickest way to set a hanging indent? (Pick one answer.)**

1. Use the **Paragraphs** dialog box.
2. Slide the **Hanging Indent** marker along the horizontal ruler to the required position.
3. Use the **Page Setup** dialog box.

# Test 4, question 2: Answer

Slide the **Hanging Indent** marker along the horizontal ruler to the required position.

This is a quick way of setting the hanging indent position.

# Lesson 5

## **Word count**

# Word count



Word can help you check document statistics

You have to write a 2000–word article, but how do you know when you're done?

Have you ever had to count characters, words, or paragraphs as you work?

A convenient feature in Word does this for you. Although it's called **Word Count**, it counts a lot more than just words.

# Basic counting

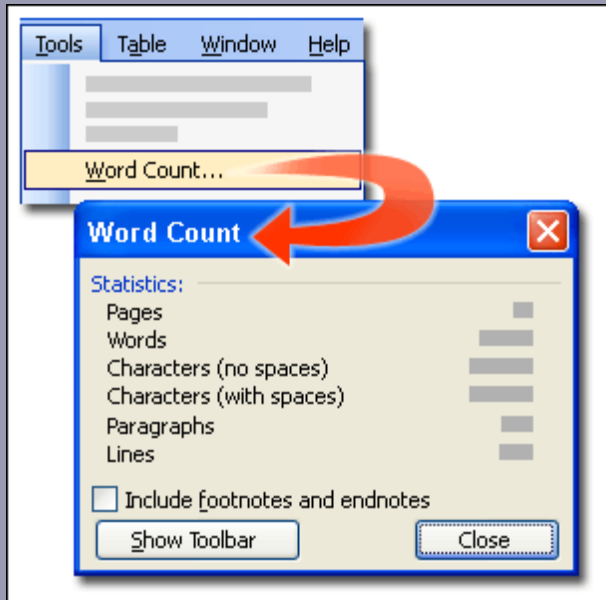

The **Word Count** command is on the **Tools** menu.

In the Word Count dialog box, you can choose what you want to count: pages, words, characters (with or without spaces), paragraphs, or lines.

For document statistics, click **Word Count**.

# Word Count toolbar

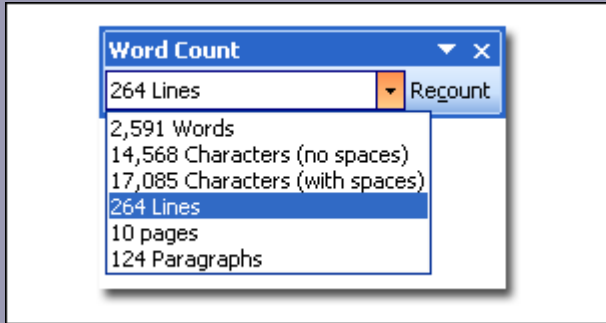

The **Word Count** toolbar

The **Word Count** toolbar is really useful if you want to keep count of things as you work.

Rather than going to the **Word Count** command every time, just open the toolbar.

# Word Count toolbar

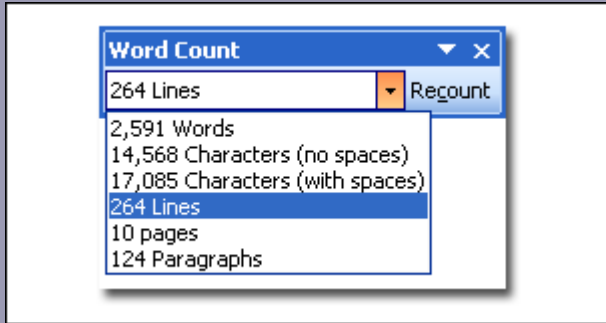

The **Word Count** toolbar

In the toolbar, you use the drop-down list to choose which element—words, lines, or pages—you want to count.

Click **Recount** whenever you want to see the latest total.

# Word Count toolbar

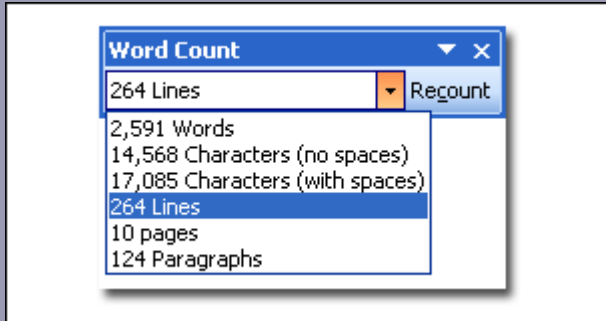

The **Word Count** toolbar

The toolbar will use the current setting in the **Word Count** dialog box for including footnotes and endnotes.

To open the **Word Count** toolbar:

- Click **Show Toolbar** in the **Word Count** dialog box. OR:
- From the **View** menu, select **Toolbars**, and then select **Word Count**.

# Suggestions for practice

1. Count words and characters.
2. Count as you work.

[Online practice](#) (requires Word 2003)

# Test 5, question 1

If you want to know how many characters (including spaces) are in a document, what Word feature do you use? (Pick one answer.)

1. **Character Count.**
2. **Statistics** tab in the **Properties** dialog box.
3. **Word Count.**
4. Count them by hand.

# Test 5, question 1: Answer

## Word Count.

Word Count can count words, but it also counts characters, lines, pages, and paragraphs.

# Test 5, question 2

Which of these is a way to open the **Word Count** dialog box? (Pick one answer.)

1. On the **Tools** menu, click **Word Count**.
2. Select the **Word Count** toolbar in the **Customize** dialog box.
3. Click **Word Count** on the **Toolbar** menu.
4. Click **Show Toolbar** in the **Word Count** dialog box.

# Test 5, question 2: Answer

On the **Tools** menu, click **Word Count**.

The Word Count dialog box appears as a result.

# Quick Reference Card

For a summary of the tasks covered in this course, view the [Quick Reference Card](#).